



# 109 SERIES SMP



Poppet Valve closing system.  
BSP, NPTF, SAE/ORB threads. Other threads available upon request.

## • Materials

	CARBON STEEL	STAINLESS STEEL
Body	Carbon Steel EN-10277-3	AISI 316
Seals	NBR, Viton or EPDM	NBR, Viton or EPDM
Back-up-ring	PTFE	PTFE
Balls	AISI 1010/1015	AISI316 W. 14401
Springs	Carbon Steel DIN 17233/84(B)	AISI302 DIN 17224

• **Applications:** Designed for Oil hydraulic Applications according to European Directive 97.23.EC

## • Equivalence

SM Series

## • Working temperature (Seals)

	NBR	Viton	EPDM
+	+100°C	+200°C	+150°C
-	-30°C	-10°C	-40°C

## • Sectors

Carbon Steel → Industrial.

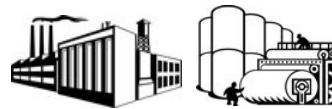

Stainless Steel → Chemical, Industrial, Offshore.



## MODEL STRUCTURE

Example:

### 109.12111 BB

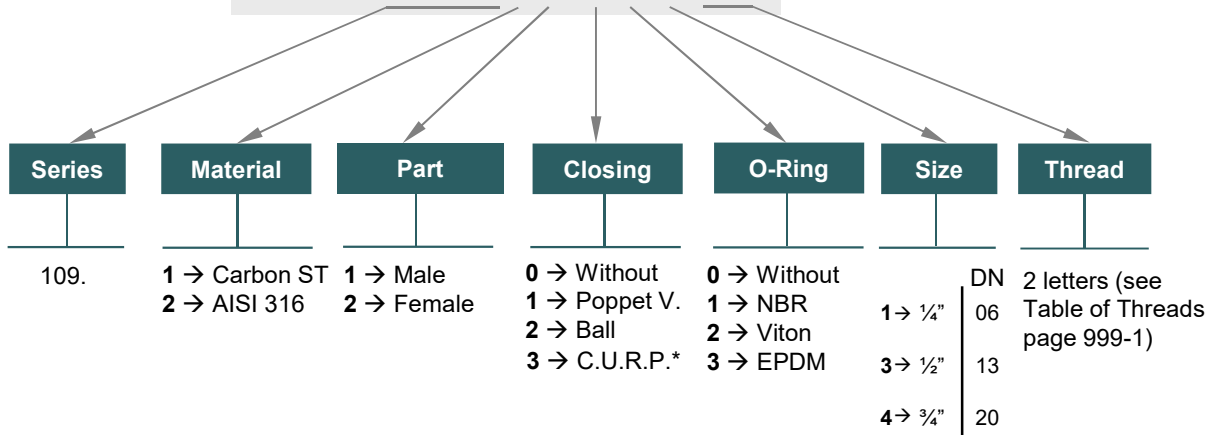

## 109-1



# 109 SERIES SMP



## MALE

DN	CH1	L1	ØF	L
06	19	38	14,10	76
13	27	46	23,55	92
20	36	56	31,45	112

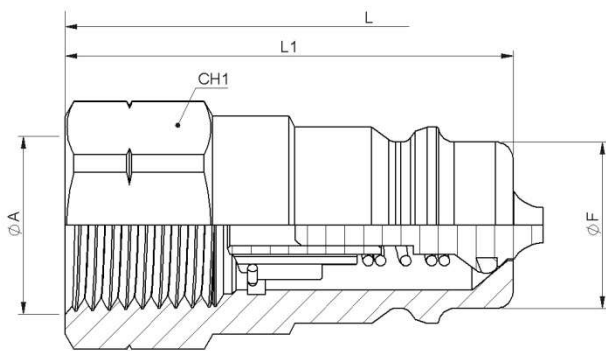

## STANDARD CARBON STEEL MODELS

DN	ØA	MALE	FEMALE	
06	1/4" BSP	109.11111AB	109.12111AB	410Bar
	1/4" NPTF	109.11111BB	109.12111BB	
	1/2" BSP	109.11113AD	109.12113AD	
13	1/2" NPTF	109.11113BD	109.12113BD	410Bar
	3/4" - 16ORB	109.11113GF	109.12113GF	
	7/8" 14ORB	109.11113GH	109.12113GH	
20	3/4" BSP	109.11114AE	109.12114AE	310Bar
	3/4" NPTF	109.11114BE	109.12114BE	
	1 1/16"-12ORB	109.11114GK	109.12114GK	

## FEMALE

DN	CH2	L2	ØD	L
06	19	57,70	27	76
13	27	74	42	92
20	36	90	52	112

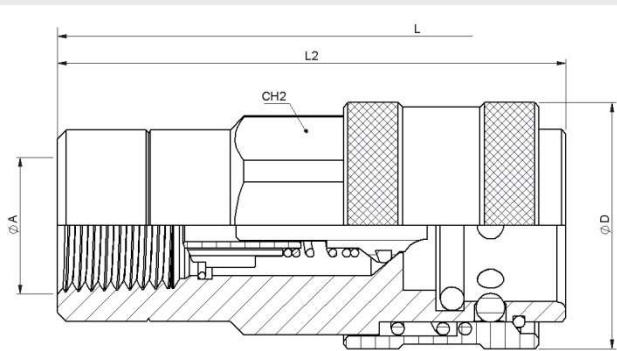



# 109 SERIES SMP

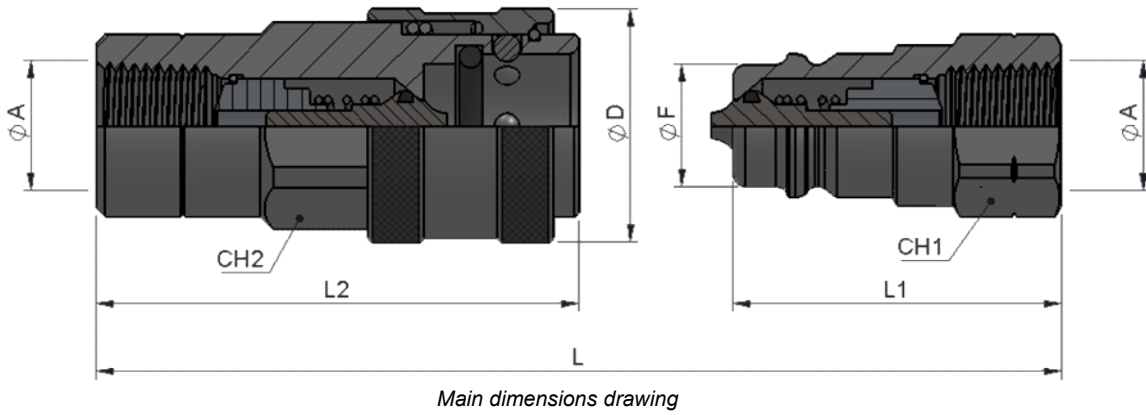

## TECHNICAL DATA

DN	Rated Flow	Min Burst Pressure (bar)			Max. Working Pressure
		Male	Female	Coupled	
06	15 l/m	1500	1600	1300	410 Bar
13	50 l/m	1400	1500	1300	410 Bar
20	110 l/m	1250	1400	1250	310 Bar

Test performed according to ISO 18869

