



432 SERIES

V3MT DIN 2353



Calibrated steel manufacturing.
Available with or without mounting holes.
Thread combination available upon request of minimum quantities.

• Materials

Carbon Steel *EN -10277-3*
Seals: **NBR, Viton or EPDM**
Seating Ball: *Poliamida 6*.
Handle: **ZAMAK-5**

• Working temperature (O-ring)

	NBR	Viton	EPDM
	+100°C	+200°C	+150°C
	-30°C	-10°C	-40°C

• **Applications:** Designed for Oil hydraulic Applications
Hammer Application

• **Sectors:** Industrial, Agricultural.



• Equivalence

PISTER BK3
MHA BK3
HYDAC KHB3k

MODEL STRUCTURE

Example:

432.1013 KD

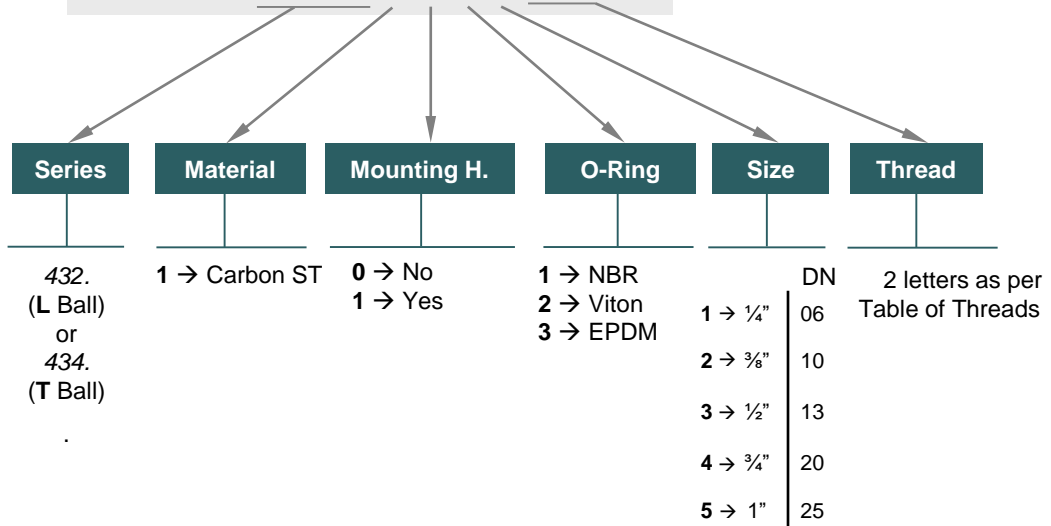

432-3



432 SERIES

V3MT DIN 2353

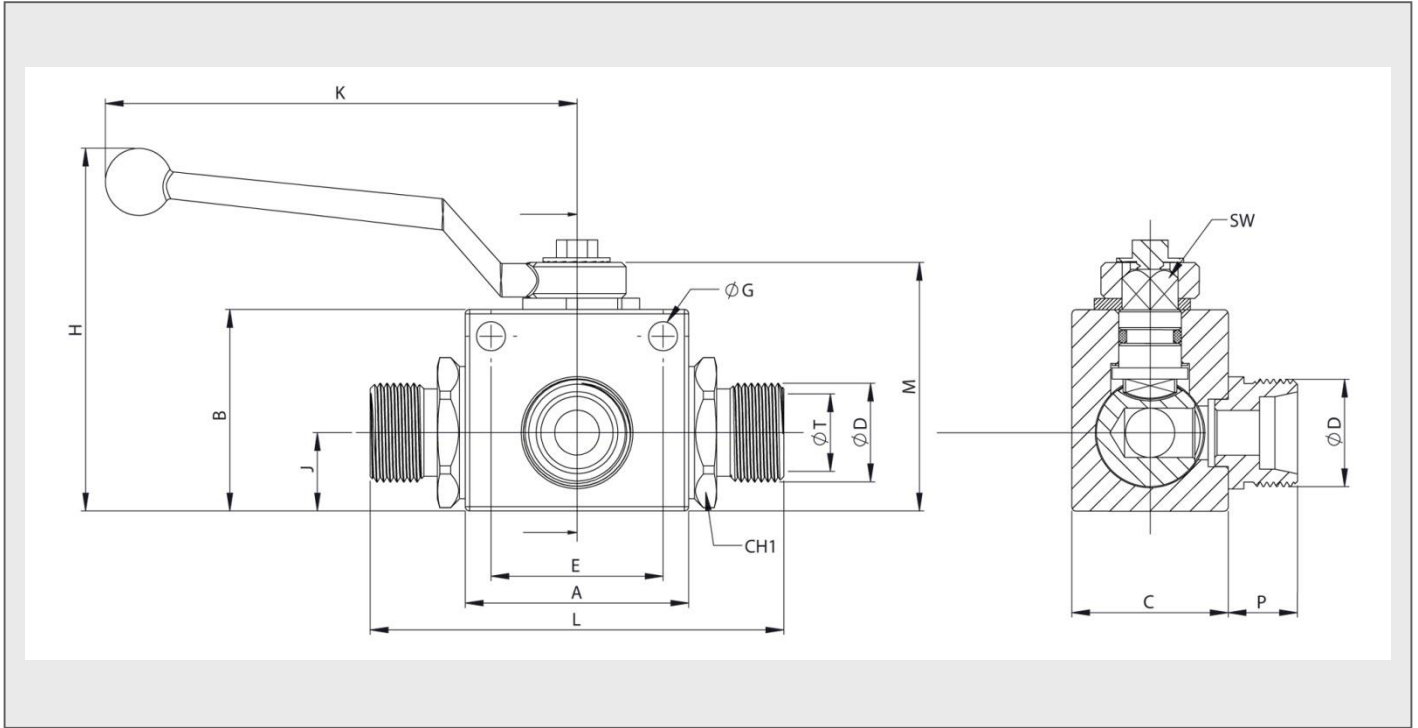

(A dimension)

STANDARD MODELS

DN	D	ØT	With M.H.	Without M.H.		CH1	L	A	B	M	K	H	J	C	SW	ØG	E	P			
06	M12x1,5	6L	432.1111JB	432.1011JB	500Bar	22	78,60														
	M14x1,5	8L	432.1111JC	432.1011JC			79,60														13
	M16x1,5	10L	432.1111JD	432.1011JD			78,60	40	35	45,50	105,50	71	13	26	8,90	4,50	31,50				
	M16x1,5	8S	432.1111KD	432.1011KD			79,60														14
	M18x1,5	10S	432.1111KE	432.1011KE			79,60														14
10	M16x1,5	10L	432.1112JD	432.1012JD	500Bar	27	77,40												14		
	M18x1,5	12L	432.1112JE	432.1012JE			77,40													15	
	M22x1,5	15L	432.1112JG	432.1012JG			79,40	45	40	50,50	105,50	76	16	32	8,90	5,20	31,50			24	
	M20x1,5	12S	432.1112KF	432.1012KF																	24
	M22x1,5	14S	432.1112KG	432.1012KG																	24
13	M22x1,5	15L	432.1113JG	432.1013JG	400Bar	41															
	M26x1,5	18L	432.1113JI	432.1013JI			92,50	50	45	55,50	105,50	81	17,50	35	8,90	6,50	38,50	15,50			
	M24x1,5	16S	432.1113KH	432.1013KH																	
	M30x2	20S	432.1113KJ	432.1013KJ			98,50														
	M30x2	22L	432.1114JJ	432.1014JJ			108,40														
20	M30x2	20S	432.1114KJ	432.1014KJ	400Bar	41	114,40	60	58	73	159,50	108	23	50	13,90	6,50	48,50	17			
	M36x2	25S	432.1114KK	432.1014KK			114,40														
	M36x2	25S	432.1114KK	432.1014KK																	
25	M36x2	28L	432.1115JK	432.1015JK	350Bar	46	128,50	65	65	80	159,50	115	27,50	57	13,90	8,50	50,50	25			
	M42x2	30S	432.1115KL	432.1015KL																	

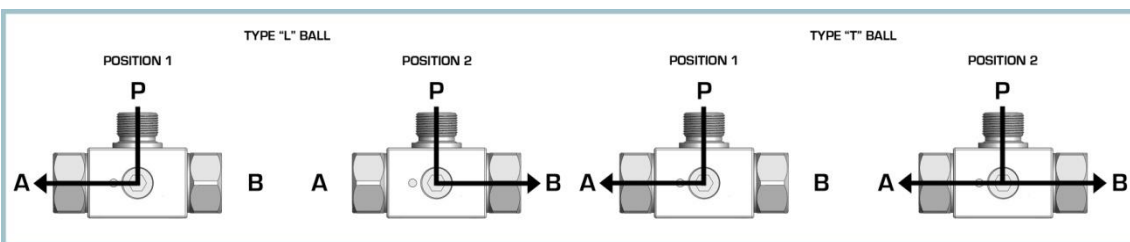

432-4